

# Enhancement of Power Quality Problem By Using Dynamic Voltage Restorer

Vijayatai P Kamble<sup>1</sup>, Prof.Naveen Kumar Mucha<sup>2</sup>

Dept of Electrical Engineering Matsyodari Shikshan Sansthas College of Engineering and Technology, Jalna, India<sup>1</sup>  
Asst Professor, Dept of Electrical Engineering, Matsyodari Shikshan Sansthas College of Engineering and Technology, Jalna, India<sup>2</sup>

**Abstract:** The Dynamic Voltage Restorer (DVR), which is the most efficient and effective modern custom power device used in power distribution networks to protect customers with an uninterrupted flow of energy at smooth sinusoidal voltage at contracted magnitude & frequency have large nonlinear loads, purity of the waveform of supplies is lost .this ends are producing many power quality problems from various disturbances of the power supply. this paper presents the study & analysis enhancement of power quality problems ,voltage sag & swells with the applications its by using proposed control DVR techniques used. At present, most of DVR use feed-forward control because of the compensation response time requirement, this kind of control may introduce steady state error and on-site calibration problems. discrete PWM-based control scheme is implemented, with reference to DVR. The aim of the control scheme is to maintain a constant voltage magnitude at the sensitive load point, under the system disturbance .simulation results show the capability of the DVR to control conditions.

**Keywords:** Dynamic Voltage Restorer (DVR), discrete pwm based control scheme, voltage sag, voltage swell, MATLAB.

## INTRODUCTION

Modern electric power systems are complex networks with hundreds of generating stations and thousands of load centres are interconnected through long power transmission and distribution networks .Now a days more focus on power quality improvement & system reliability improvement. Power quality is major concern in industries today because of enormous losses in energy and money With the advent of myriad sophisticated electrical and electronic equipment, such as computers, programmable logic controllers and variable speed drives which are very sensitive to disturbances and non-linear loads at distribution systems produces many power quality problems like voltage sags, swells and harmonics and the purity of sine waveform is lost. Voltage sags are considered to be one of the most severe disturbances to the industrial equipment's. as per power quality problems 80% of the distributions system.

According to the IEEE 1959-1995, standard voltage sag decreases 0.1 to 0.9 p.u.in the rms voltage level. at power quality problems have been identified to be of major concern to the customers are voltage sags and swells, but this project will be focusing on voltage sags/swells, as well as interruptions. While power disturbances occur on all electrical systems, the sensitivity of today's sophisticated electronic devices makes them more susceptible to the quality of power supply. For some sensitive devices, a momentary disturbance can cause scrambled data, interrupted communications, a frozen mouse, system crashes and equipment failure etc. A power voltage spike can damage valuable components. Power Quality problems encompass a wide range of disturbances such as voltage sags/swells, flicker, harmonics distortion,

impulse transient, and interruption study of power quality problems

1.voltage dip- A voltage dip is used to refer to short-term reduction in voltage of less than half a second. A voltage dip may be caused by switching operations associated with a temporary disconnection of supply, the flow of heavy current associated with the starting of a large electric motors or the flow of fault currents or the transfer of load from one power source to another

2. Voltage sag- Voltage sags can occur at any instant of time, with amplitudes ranging from 10 – 90% and a duration lasting for half a cycle to one minute.

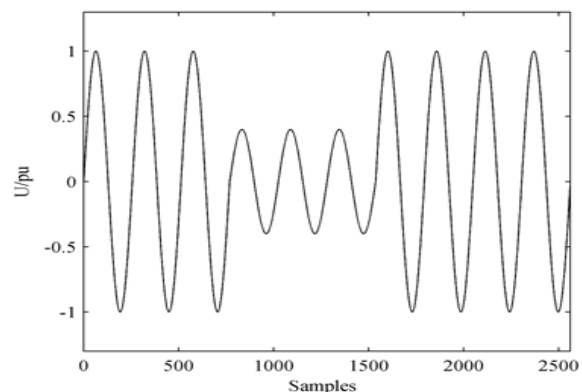

Fig. 1.1: Voltage Dip (Sag) Waveform

3. Voltage swell- Voltage swell is defined as an increase in RMS voltage or current at the power frequency for durations from 0.5 cycles to 1 min.

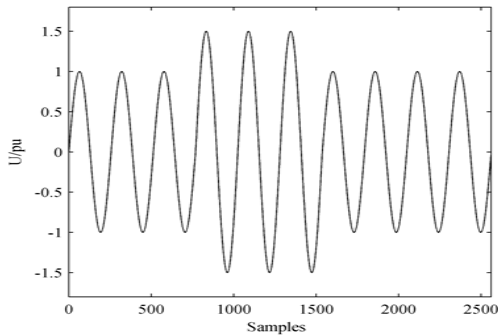

Fig. 1.2: Voltage Swell Waveform

swells control motor drive etc which can trip because of their in protective circuitry.due to create some problem & reduced life span of the compoent.

4. Voltage spikes,impulses or surges:These are the RMS used to describe abrupt, very brief increases in voltage value.

5.Voltage transient: They are temporary, undesirable voltages that appear on the power supply line. Transients are high over-voltage disturbances (up to 20KV) that last for a very short time

5.1.Harmonics- The fundamental frequency of the AC electric power distribution system is 50 Hz. A harmonic frequency is any sinusoidal frequency, which is a multiple of the fundamental frequency. Harmonic frequencies can be even or odd multiples of the sinusoidal fundamental frequency.

5.2 Flickers- Visual irritation and introduction of many harmonic components in the supply power and their associated ill effects.

various reasons to create causes related dip ,sag, swells, transients &spikes effect for vltg sag &swells these are problems  
solution for power quality problems

The basic Custom Power Device are used power quality improvement like FACTS devices used specially for related distribution system control fault disturbance to clear by the device protect to the system using this device DSTATCOM Distributions Static Synchronous Compensator , DVR Dynamic Voltage Restorer ,UPQC Unified Power Quality Conditioner etc .Among these devices ,DVR is most effective & efficient Custom Power Device. because use of the device is less cost ,smaller size & taking very fast response towards the disturbances.

**BASIC CONFIGURATION OF DVR**

Main purpose of DVR is to inject the desired voltage quantity in series with the supply with help of injection transformer whenever voltage sag is detected .The basic component connected to the block diagram show

The general configuration of the DVR consists of:

- i. An Injection/ Booster transformer
- ii. A Harmonic filter
- iii. Storage Devices

- iv. A Voltage Source Converter (VSC)
- v. DC charging circuit
- vi. A Control and Protection system

DVR connect in series with injection transformer ,low pass filter ,inverter & control technique use of Discrete PWM proportional controller are use with connect supply provide by energy storage device ie DC link. Before injecting the inverter output to the system it must filtered harmonics due to switching function in the inverter eliminated .in this should be noted that when using the DVR in real situation injection transformer connect the parallel with a bypass switch is connected when there is no disturbances in voltage DVR operate as short circuited by the switch minimise the losses .DVR

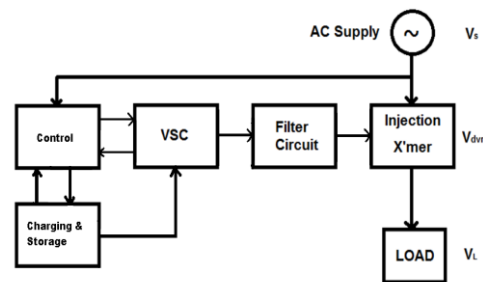

Operating Modes of DVR

The basic function of the DVR is to inject a dynamically controlled voltage VDVR generated by a forced commutated converter in series to the bus voltage by means of a booster transformer. The momentary amplitudes of the three injected phase voltages are controlled such as to eliminate any detrimental effects of a bus fault to the load voltage VL. This means that any differential voltages caused by transient disturbances in the ac feeder will be compensated by an equivalent voltage generated by the converter and injected on the medium voltage level through the booster transformer.

The DVR has three modes of operation which are

- 1. Protection mode
- 2. Standby mode
- 3. Injection/boost mode.

1 protection mode

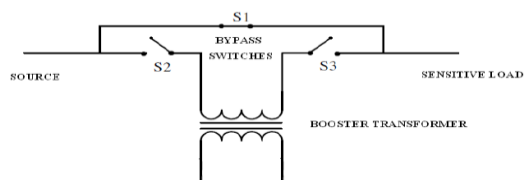

If the over current on the load side exceeds a permissible limit due to short circuit on the load or large inrush current, the DVR will be isolated from the systems by using the bypass switches (S2 and S3 will open) and supplying another path for current (S1 will be closed). The required output voltage is obtained by using pulse-width modulation switching pattern. As the controller will have to supply active as well as reactive power, some kind of energy storage is needed.

2. Standby mode: In the standby mode the booster transformer's low voltage winding is shorted through the converter. No switching of semiconductors occurs in this mode of operation and the full load current will pass through the primary.

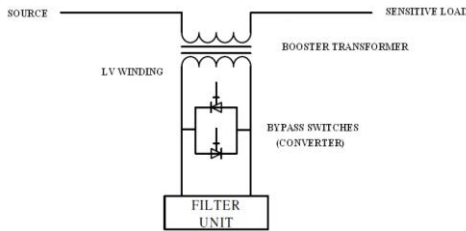

3. Injection/boost mode ( $V_{DVR} > 0$ ): In the Injection/Boost mode the DVR is injecting a compensating voltage through the booster transformer due to the detection of disturbance in the supply voltage. The basic idea of a DVR is to inject the missing voltage cycles into the system through series injection transformer whenever voltage sags are present in the system supply voltage. As a consequence, sag is unseen by the loads. During normal operation, the capacitor receives energy from the main supply source. When voltage dip or sags are detected, the capacitor delivers dc supply to the inverter. The inverter ensures that only the missing voltage is injected to the transformer. A relatively small capacitor is present on dc side of the PWM solid state inverter and the voltage over this capacitor is kept constant by exchanging energy with the energy storage reservoir. The required output voltage is obtained by using pulse-width modulation switching pattern. As the controller will have to supply active as well some kind of energy used. Basic operational principal of DVR: DVR is a recently proposed series connected solid state device that injects voltage into the system in order to regulate the load side voltage. It is normally installed in a distribution system between the supply and the critical load feeder at the point of common coupling (PCC). Other than voltage sags and swells compensation, DVR can also be added in other features like line voltage harmonics compensation, reduction of transients in voltage and fault current limitations. DVR, Dynamic Voltage Restorer is a distribution voltage DC-to-AC solid-state switching converter that injects three single phase AC output voltages in series with the distribution feeder and in synchronicity with the voltages of the distribution system. By injecting voltages of controllable amplitude, phase angle, and frequency

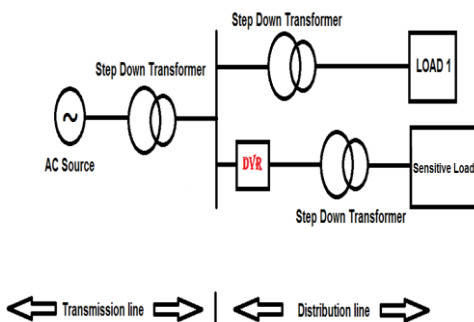

(harmonic) into the distribution feeder in instantaneous real time via a series-injection transformer, the DVR can restore the quality of voltage at its load side terminals when the quality of the source side terminal voltage is distorted due to sensitive loads. At present, most of DVR use feed-forward control because of the compensation response time requirement, this kind of control may introduce steady state error and on-site calibration problems. Although closed-loop PI regulation could not meet the dynamic response requirement, this paper demonstrates that a closed-loop nonlinear state variable control algorithm is a viable industrial solution. Practical issues, such as fault type analysis and controller design method, are included in.

**CALCULATION IN RELATED TO DVR**

The system impedance  $Z_{TH}$  depends on the fault level of the load bus. When the system Voltage ( $V_{TH}$ ) drops, the DVR injects a series voltage  $V_{DVR}$  through the injection transformer so that the desired load voltage magnitude  $V_L$  can be maintained. The series injected voltage of the DVR can be written as

$$V_{DVR} = V_L + Z_{TH} I_L - V_{TH} \dots \dots \dots (1)$$

Where

- $V_L$ : The desired load voltage magnitude
- $Z_{TH}$ : The load impedance.
- $I_L$ : The load current
- $V_{TH}$ : The system voltage during fault condition

The load current  $I_L$  is given by,

$$I_L = \frac{P_L + jQ_L}{V} \dots \dots \dots (2)$$

When  $V_L$  is considered as a reference equation can be rewritten as,

$$V_{DVR} \angle 0 = V_L \angle 0 + Z_{TH} \angle (\beta - \theta) - V_{TH} \angle \delta \dots \dots \dots (3)$$

$\beta, \delta$  are angles of  $Z_{TH}, V_{TH}, V_{DVR}$  respectively and  $\theta$  is Load power angle  
 $\theta = \tan^{-1} \left( \frac{Q_L}{P_L} \right)$

The complex power injection of the DVR can be written as,  $S_{DVR} = V_{DVR} I_L \dots \dots \dots (4)$   
 It requires the injection of only reactive power and the DVR itself is capable of generating the reactive power

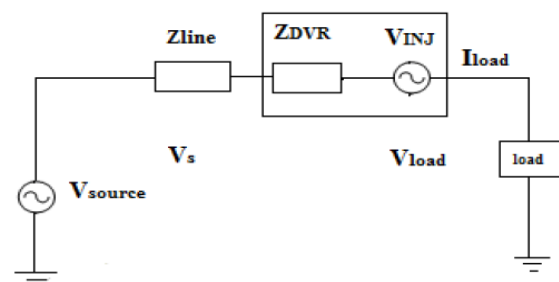

Equivalent Circuit Diagram of DVR

**PROPOSED DVR CONTROL TECHNIQUES**

**1. Discrete PWM-Based Control Scheme**

In order to mitigate the simulated voltage sags in the test system of each compensation technique, also to compensate voltage sags in practical application, a discrete PWM-based control scheme is implemented, with reference to DVR. The aim of the control scheme is to maintain a constant voltage magnitude at the sensitive load point, under the system disturbance. The control system only measures the RMS voltage at load point, for example, no reactive power measurement is required. Figure shows the DVR controller scheme implemented in MATLAB/SIMULINK. The DVR control system exerts a voltage angle control as follows an error signal is obtained by comparing the reference voltage with the RMS voltage measured at the load point. The PI controller processes the error signal and generates the required angle  $\delta$  to drive the error to zero, for example; the load RMS voltage is brought back to the reference voltage. It should be noted that, an assumption of balanced network and operating conditions are made. The modulating angle  $\delta$  or delta is applied to the PWM generators in phase A, whereas the angles for phase B and C are shifted by  $240^\circ$  or  $-120^\circ$  and  $120^\circ$  respectively.

$$V_A = \sin(\omega t + \delta)$$

$$V_B = \sin(\omega t + \delta - 2\pi/3)$$

$$V_C = \sin(\omega t + \delta + 2\pi/3)$$

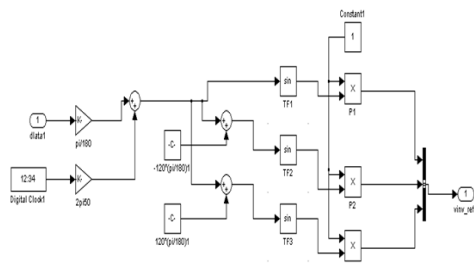

Fig. Firing Angle Controller Scheme

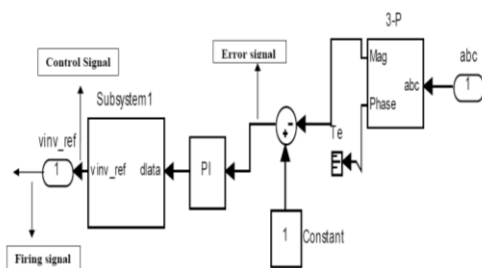
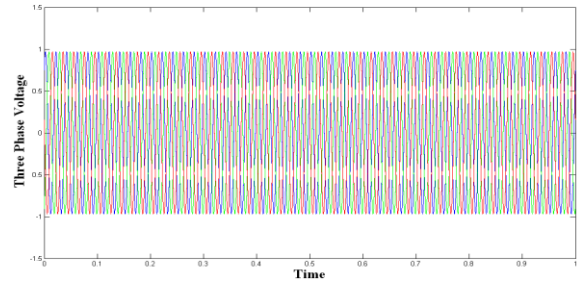

Fig 2. SIMULINK Model of DVR Controller

**SIMULATION AND RESULT**

Digital simulation is done using the blocks of Matlab/simulink and the results are presented here. The first simulation was done with no DVR and no three phase fault is applied to the system. This system shows the normal operating power system without DVR and three phase fault. Figure shows the SIMULINK model for Normal Operating Power System. Figure and figure shows the output waveform for figure .



3-Ø Voltage at Load Point, Without 3-Ø Fault, Without DVR

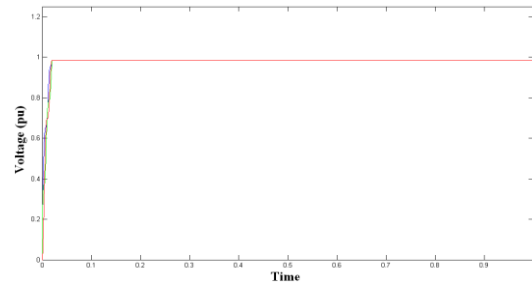

P.U Voltage at Load Point, Without 3-Ø Fault, Without DVR

The second simulation is done in figure with no DVR and a three phase fault is applied to the system at point with fault resistance of 0.66 p.u for a time duration of 200 ms. The third simulation is carried out in figure 5.9 at the same scenario as above but a DVR is now introduced at the load side to compensate the voltage sag occurred due to the three phase fault applied.

Figure shows the p.u. voltage at load point when the system operates with no DVR and a three phase fault is applied to the system. When the DVR is in operation the voltage interruption is compensated almost completely and the RMS voltage at the sensitive load point is maintained at normal condition.

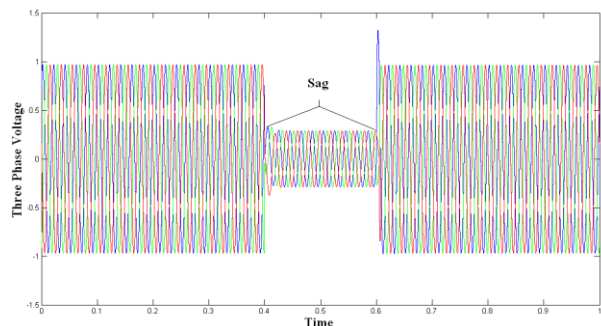

3-Ø Voltage at Load Point, With 3-Ø Fault, Without DVR

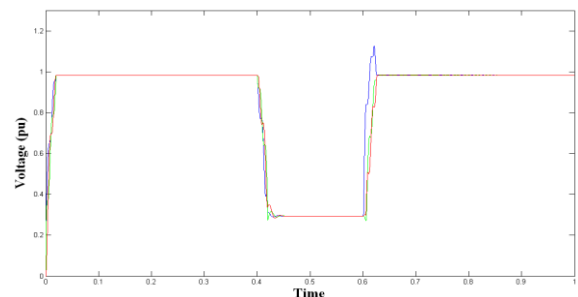

P.U Voltage at Load Point, With 3-Ø Fault, Without DVR



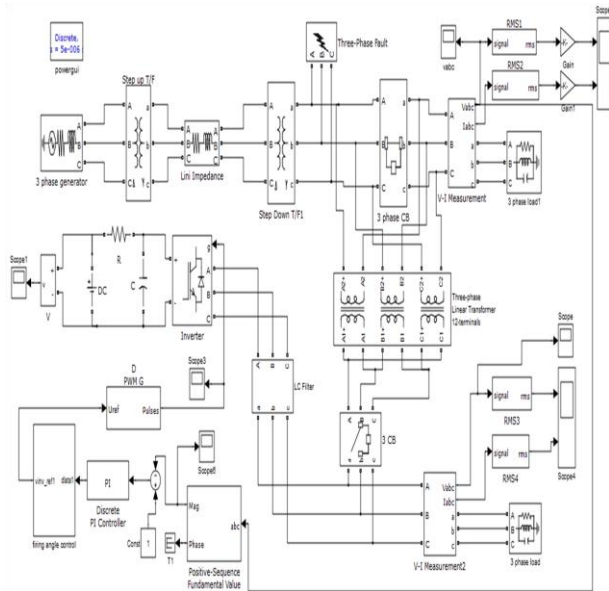

Simulink Model of DVR in Power System

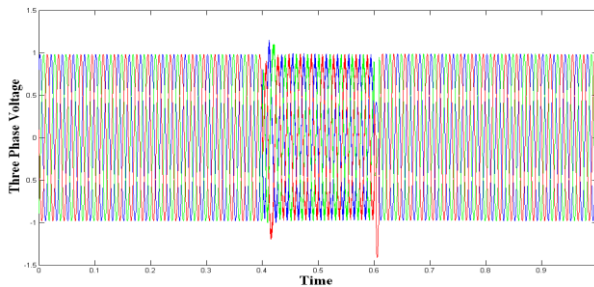

3-Ø Voltage at Load Point, With 3-Ø Fault, With DVR

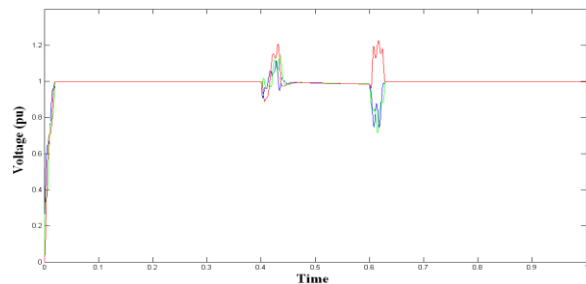

P.U Voltage at Load Point, With 3-Ø Fault, With DVR

**CONCLUSION**

From the various research paper related to power quality problems, it has found that there are so many power quality issues like voltage sag, swell, spikes, transient and harmonic which is very harmful to power system. In this regard, so many techniques are used to eliminate the power quality problems like lightning arrester, Active Power Filters (APF), Energy Storage Systems, Thyristor Based Static Switches, Distribution STATIC Synchronous compensators (DSTATCOM) etc .Dynamic voltage restorer is a effective device use to solve major power quality problem i.e. voltage sag. In this research, dynamic voltage restorer model is used to eliminate power quality problems. It works effectively and reduces the sag and minimize the harmonic which come from voltage source converter.

**REFERENCES**

- [1] Chellali Benachaiba, Brahim Ferdi, Voltage Quality Improvement Using DVR Electrical Power Quality and Utilization, Journal Vol. XIV, No. 1, 2008.
- [2] H. Kim, Minimal Energy Control for A Dynamic Voltage Restorer, Power Conversion Conference, PCC Osaka 2002, Vol. 2, pp. 428-433.
- [3] D. Vilathgamuwa, A. RanjithPerera, and S. Choi, Voltage Sag Compensation With Energy Optimized Dynamic Voltage Restorer, IEEE Transactions on Power Delivery, Vol. 18, No. 3, July 2003, pp. 928-936.
- [4] S. S. Choi, B. H. Li, and D. M. Vilathgamuwa, Dynamic Voltage Restoration with Minimum Energy Injection, IEEE Transactions on Power Systems, Vol. 15, No. 1, February 2000, pp. 51-57.
- [5] J. Nielsen, F. Blaabjerg and N. Mohan, Control Strategies for Dynamic Voltage Restorer. Compensating Voltage Sags with Phase Jump, Applied Power Electronics Conference and Exposition, EPC 2001, Vol. 2, pp. 1267-1273
- [6] B. H. Li, S. S. Choi, and D. M. Vilathgamuwa, A New Control Strategy For Energy-Saving Dynamic Voltage Restoration” Power Engineering Society Summer Meeting 2000, Vol. 2, pp. 1103-1108.
- [7] M.H.J. Bollen, Voltage, Power And Current Ratings Of Series Voltage Controllers, Power Engineering Society Winter Meeting 2000, Vol. 4, pp. 2910-2915.
- [8] B.H. Li, S.S. Choi and D.M. Vilathgamuwa, Transformer less Dynamic Voltage Restorer, IEE Proc. – Generation, Transmission and Distribution, Vol. 149, No. 3, May 2002, pp. 263-273.
- [9] Y.H. Chung, G.H. Kwon, Z.B. Park and K. Y. Lim, Dynamic Voltage Regulator with Solid-State Switched Tap Changer, Quality and Security of Electric Power Delivery Systems, CIGRE/PES 2003 Int. Symposium, Conference Proceedings, pp.105-108.
- [10] S.U. Ahn, J.A. Jardini, M. Masuda, F.A.T. Silva, S. Copeliovitch, L. Matakas, W. Komatsu, M.Galassi, F.Ortiz, J. Camargo and E. R. Zanetti, Mini-DVR - Dynamic Voltage Restorer with Functions of Reactive Compensation and Active Harmonic Filter, 2004 IEEE/PES Transmission & Distributin Conference & Exposition: Latin America, Conference Proceedings, pp. 845-852.

**BIOGRAPHIES**



First Author: **Kamble Vijaya Tai Pandurang** She is the student of ME from MSS's CET Jalana- nagewadi, in Electrical Engineering Dept. she was received B.E. from P.E.S. College Of Engineering aurangabad under B.A.M.Unviersity Aurangabad



Second Author: Naveen **Kumar Mucha** He is presently working as Asst. Professor in the Dept. of Electrical Engineering, From MSS's engineering college, jalna maharashtra. He was born in andrapradesh, India, in 1984 He received B.Tech. degree in The Stream electrical & electronics engineering(EEE) from sree kavitha engineering college, J.N.T.University, Hyderabad, and M.Tech degree in Power System Controlling and Automation(PSCA) from the JITS college of engineering Warangal J.N.T.University, Hyderabad.